

CISC 322

Software/Game Architecture



Module 4: Examples of Architectures (Linux)

Ahmed E. Hassan



Linux as a Case Study: Its Extracted Software Architecture

Paper By: Ivan T. Bowman, Richard C. Holt and
Neil V. Brewster

Slides By: Jack ZhenMing Jiang



Outline

- Terminology
- Conceptual Architecture
- Concrete Architecture
- Conclusions

Terminology

- **Conceptual Architecture**
 - How developers think of a system; Relations meaningful to developers
 - Analogy: Blue Print of the House
 - By Reviewing Existing Documentation
 - Essential Relations
- **Concrete Architecture**
 - Relations that exists in a system
 - Analogy: Actual Architecture of the House
 - By Examining the Source Code
 - Implementation Specific Knowledge

The Linux Kernel

- Responsible for process, memory, and hardware device management
 - Different from the Linux System
- Linux System: 10 KLOC in 1991 to 1.5 MLOC in 1998
- The studied Linux Kernel is 800 KLOC
- Open Source

Conceptual Architecture – Top Level

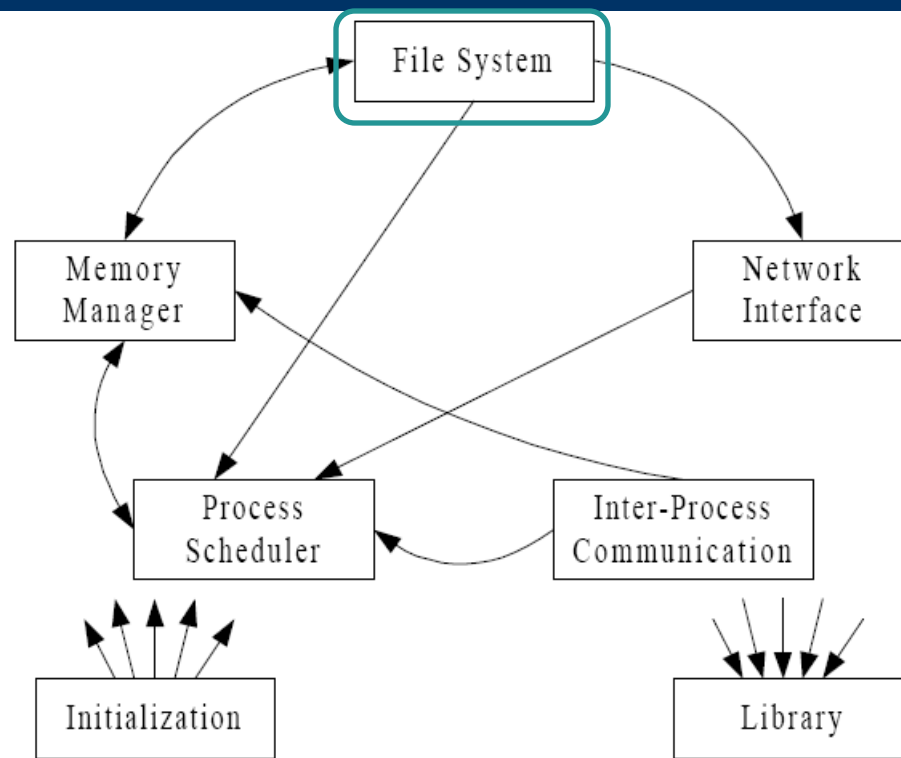

Legend: Subsystem ——— depends on ———>

Conceptual Architecture – File System

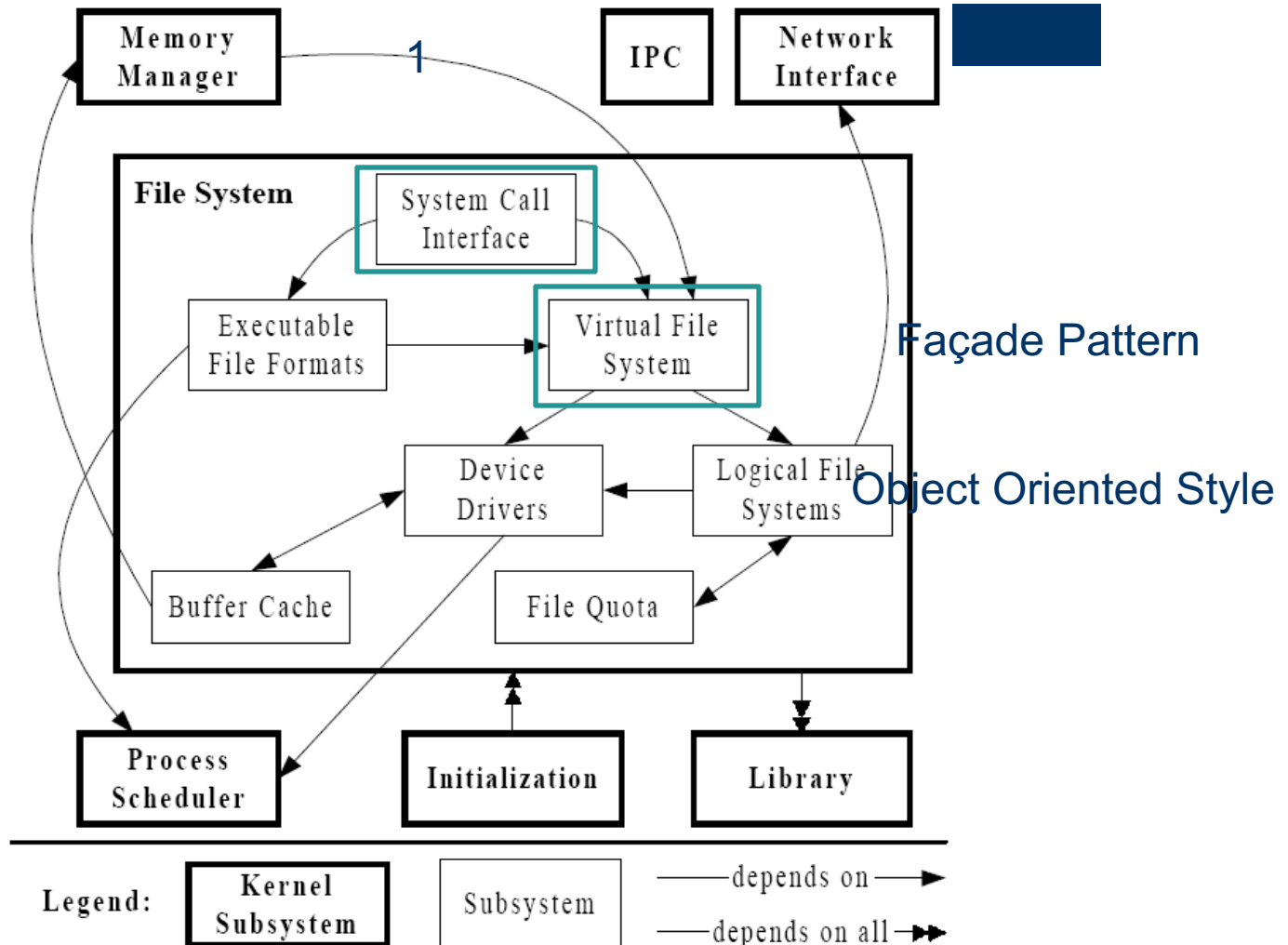

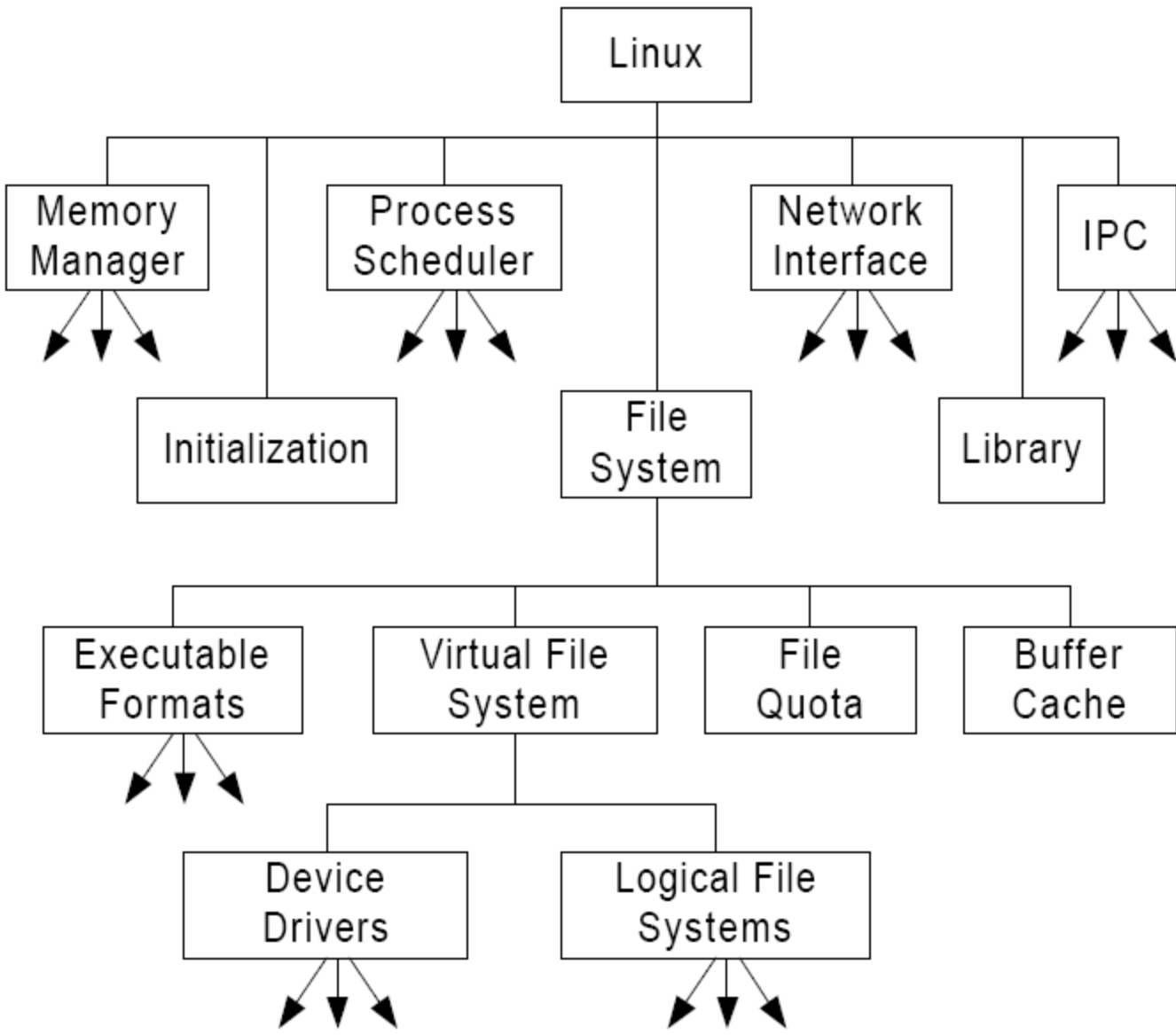

Legend:

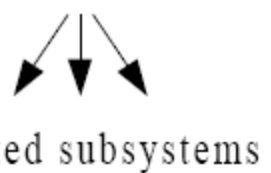
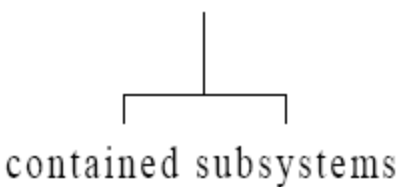
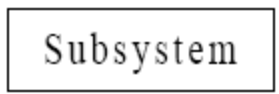

Concrete Architecture – Top Level

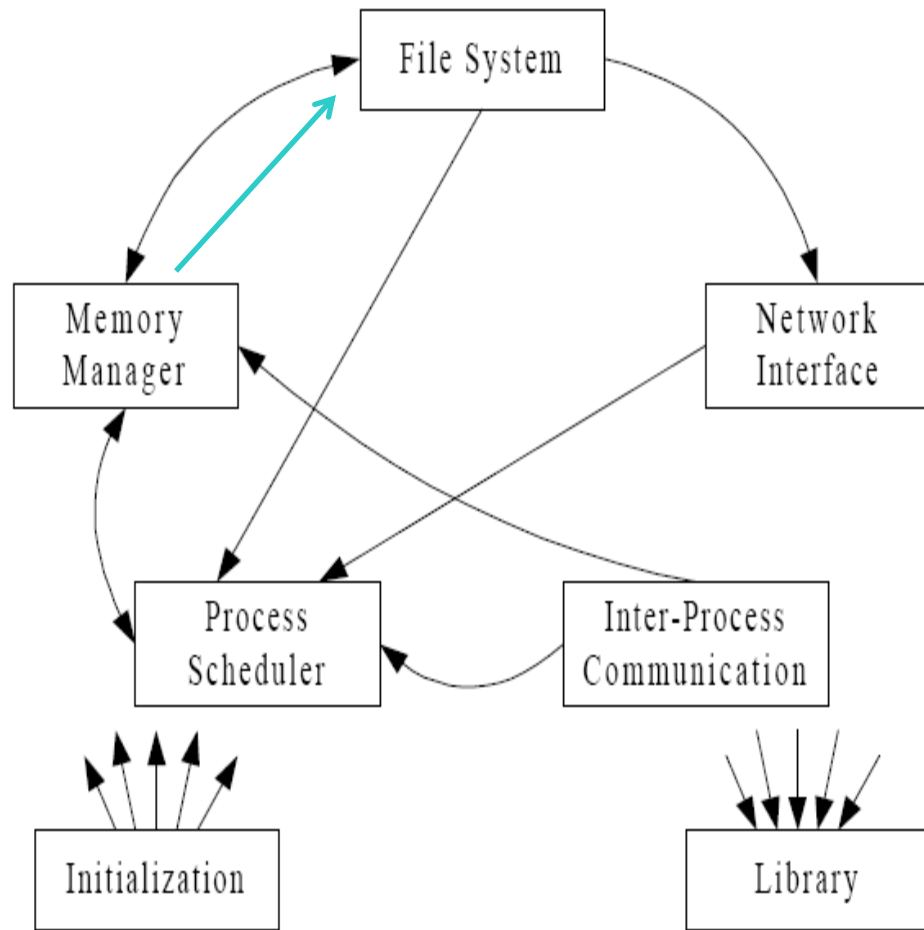

Legend: Subsystem — depends on —>

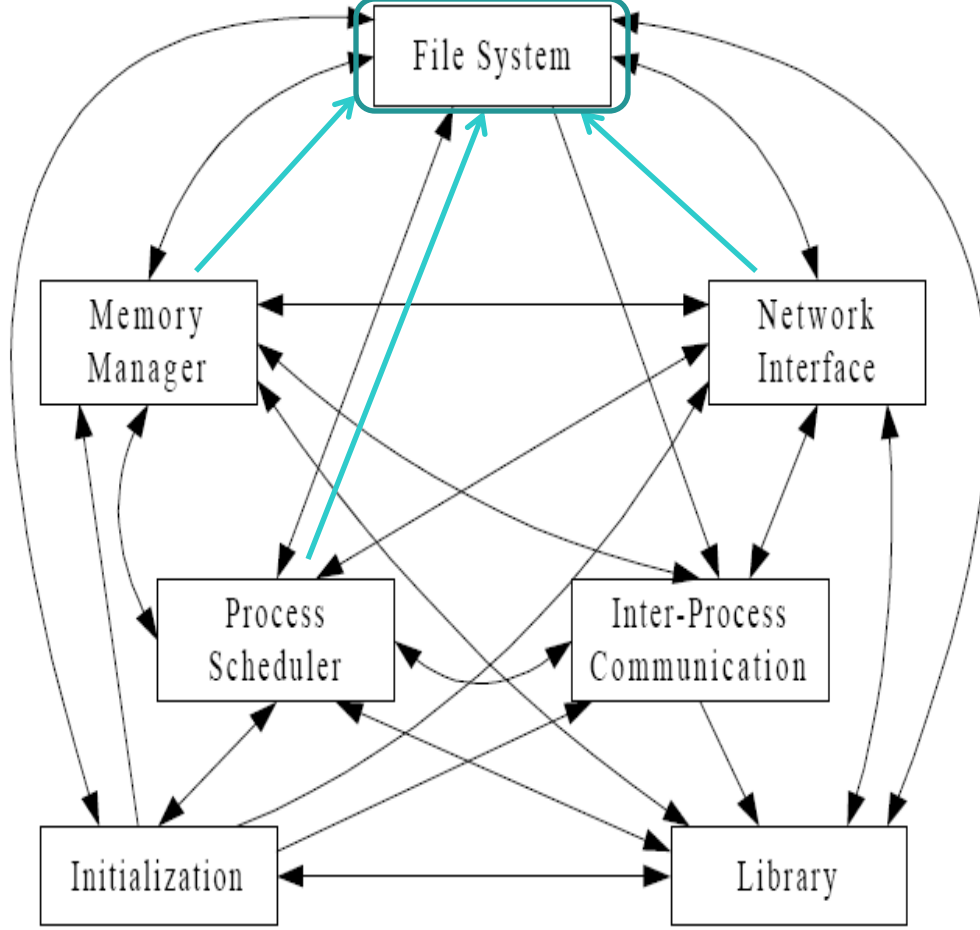

Legend: Subsystem — extracted dependency —>

Concrete Architecture – File System

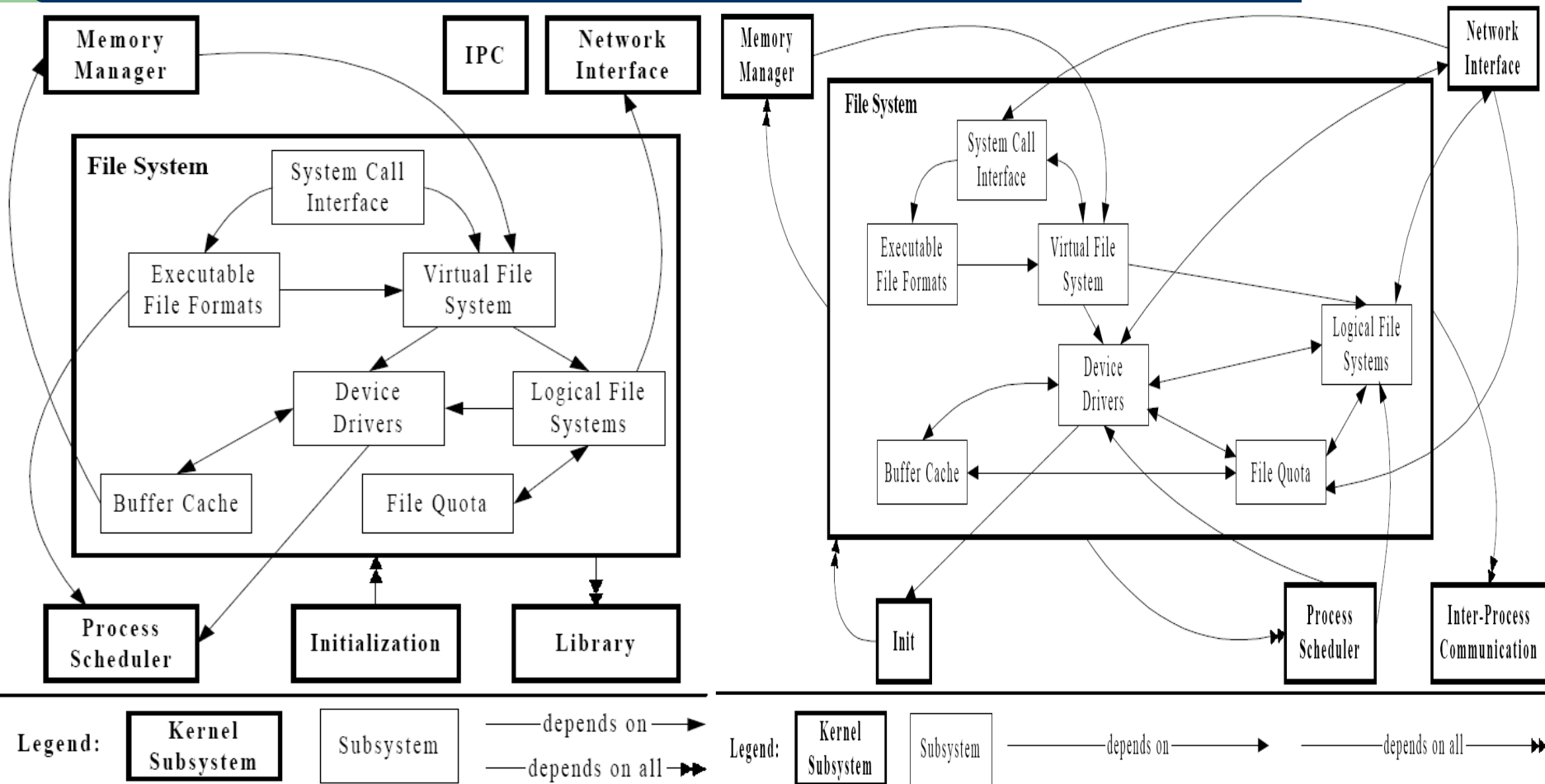

Concrete Architecture – File System

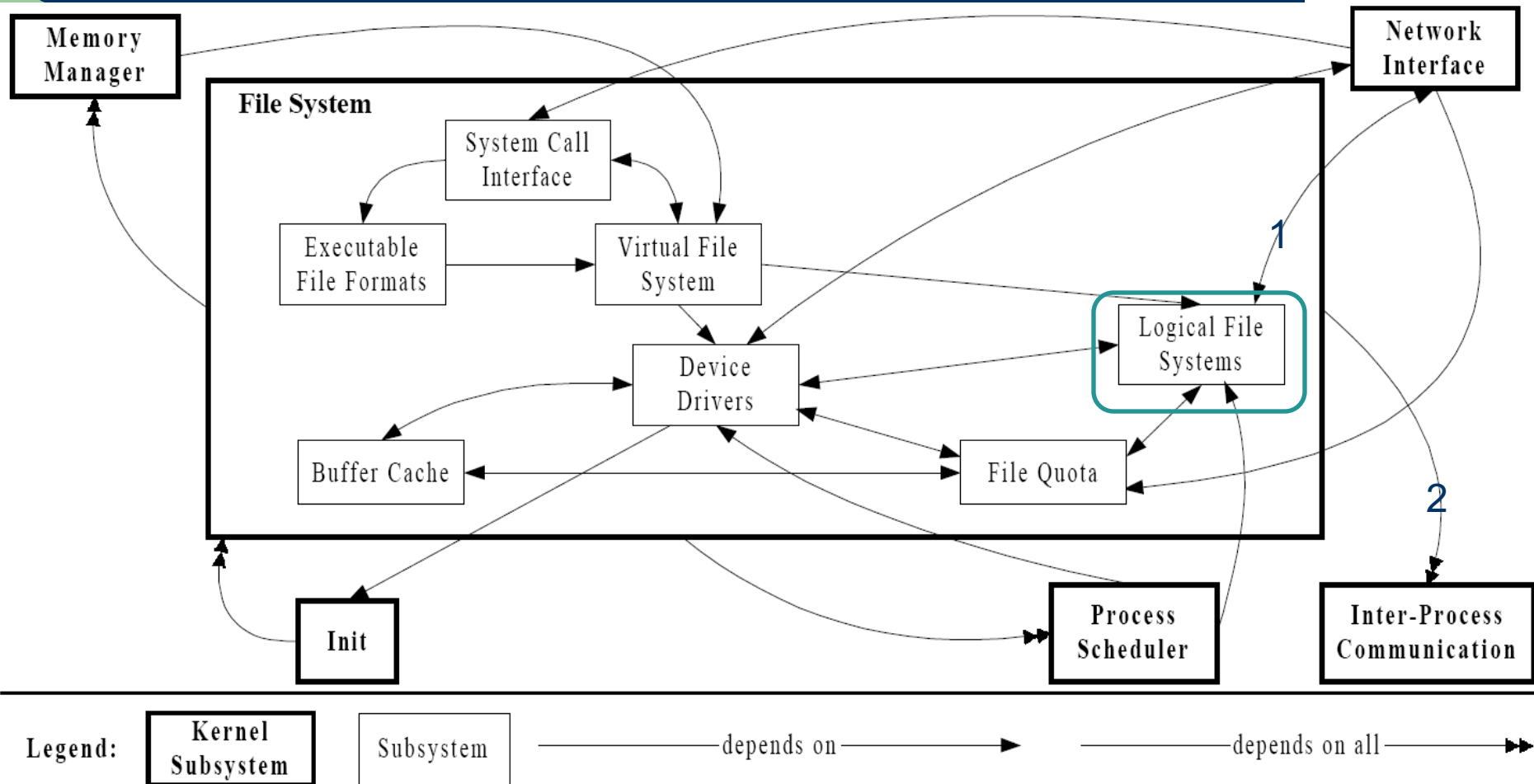

Concrete Architecture – Logical File System

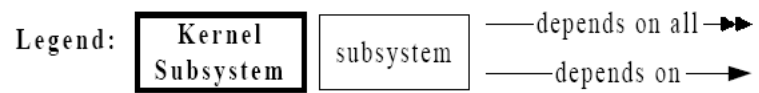
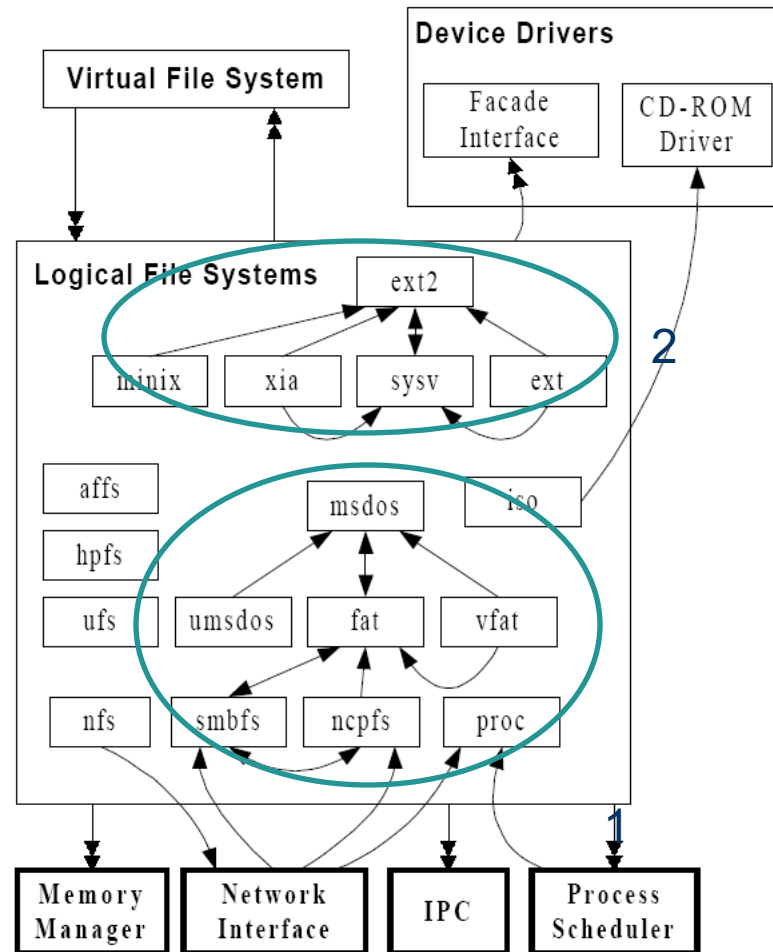

Why Conceptual Architecture and Concrete Architecture Not Match?

- Missing Relations in Conceptual Architecture
- More Functionalities
 - For example, Process Scheduler
- Use Different Mechanisms
- Improve Efficiency by Bypassing Existing Interfaces
- Exist for Developer Expediency
 - “The read-only stuff doesn’t really belong here, but any other place is probably as bad and I don’t want to create yet another include file.”

What To Do Next?

- Restructure to Remove Unexpected Dependencies
 - Header Files
 - Lower Coupling
- Refine Conceptual Architecture
 - Not Hinder System Understanding

Conclusions

- Conceptual and Concrete Architecture for the Linux Kernel
- Similar Work Needs to Be Done for the Firefox Report
- Sample Reports:
 - Conceptual Architecture:
<http://plg.uwaterloo.ca/~itbowman/CS746G/a1/>
 - Concrete Architecture:
<http://plg.uwaterloo.ca/~itbowman/CS746G/a2/>

